



ANGEL GUARD

MONITOR · CLEAN · PROTECT · TRUST

CLARENCE

REMOTE WATER MONITORING



FEATURING SERAPH PROTECT

© 2023

Contents

3. Company profile

4. How pipework systems
can make water unsafe

6. The shortcomings of
traditional water monitoring

8. Introducing the Clarence
system

12. Seraph Protect:
Compliance, 24/7

14. Increases compliance,
saves costs

16. Case studies and testimonial

17. Net zero targets

18. Technical information
& associations

20. Data sheets

Company profile

Angel Guard is a water management company that seeks to save time, money and most importantly lives, founded on the experience of Managing Director Jonathan Waggott and Director of Sales and Marketing Elaine Waggott, both very well experienced in the world of water health and plumbing.

With its offices and manufacturing both based within the UK, Angel Guard is proud to be part of Made in Britain to encourage growth and production within the country. Each Angel Guard product has been created with the consultation of respective experts within their field to target critical issues within the water health sector.

Angel Guard are the creators of the world's first clinical washbasin unit which utilises AI technology, as well as the world's first remote water monitoring system with biofilm detection. Angel Guard has one goal - saving time, money and most importantly lives through the deployment of many innovative, scientific, and technological solutions.



Product/Innovation of the Year - Wellbeing



Innovation of the Year



Technical Innovation of the Year - Products



Clinical Washbasin of the Year

How pipework systems can make water unsafe

Nosocomial infections, and what they can lead to

Nosocomial infections, or healthcare acquired infections (HCAs) are infections contracted within a healthcare environment and not prior to or afterwards. In one year alone, HCAs were estimated to have cost NHS England alone £2.1 billion. These costs cover additional bed space, litigation costs and the cost of specialist drugs and treatment. Commonly, the cause of these infections can be found within the water systems of hospitals and other healthcare settings.

Failing to put the proper measures or remote water monitoring systems in place can cause once-safe water systems to rapidly degenerate into breeding grounds for harmful bacteria. These water systems then begin to house water-borne pathogens and gives them a greater chance for transmission.

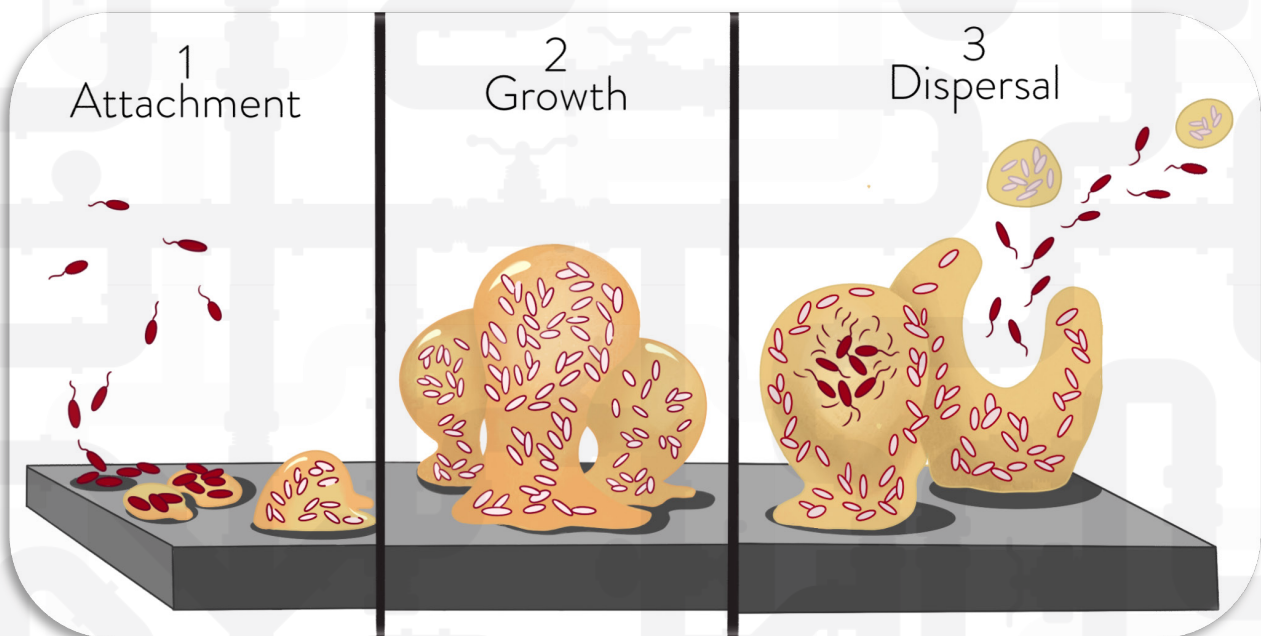

Biofilm

Bacterial biofilms are excreted by clusters of bacteria that have stuck together and attached themselves to a surface. This often tends to look like a layer of slime, when in reality it is essentially a huge colony of bacteria, able to disperse as particles through water and air. Unfortunately, biofilms pose an even bigger threat to public health, as they can be highly resistant to conventional antibiotics, which only furthers the threat of antibiotic resistant pathogens.

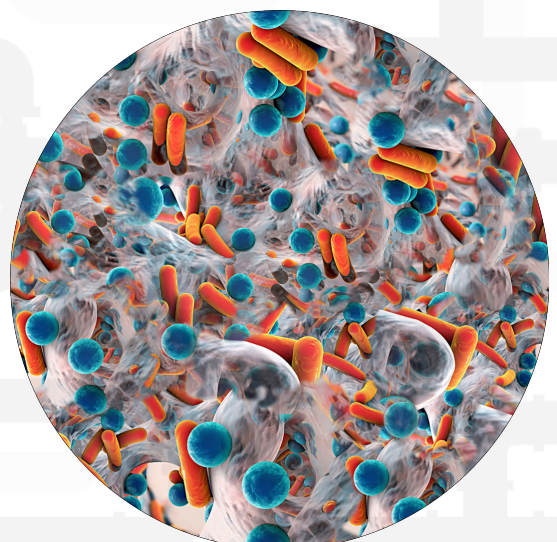

The harmful bacteria that can often be found in water systems

Including, but not limited to:

Legionella

Genus of pathogenic gram-negative bacteria. Capable of causing Legionnaire's disease, legionella grows especially quickly at temperatures between 30 degrees Celsius and 45 degrees Celsius. To ensure that your water system remains legionella-free, you will need to guarantee that your cold water is kept at under 30 degrees Celsius, and hot water kept above 55 degrees Celsius. Another essential safeguard to prevent legionella is to keep water moving and ensure suitable flushing of taps in low use areas.

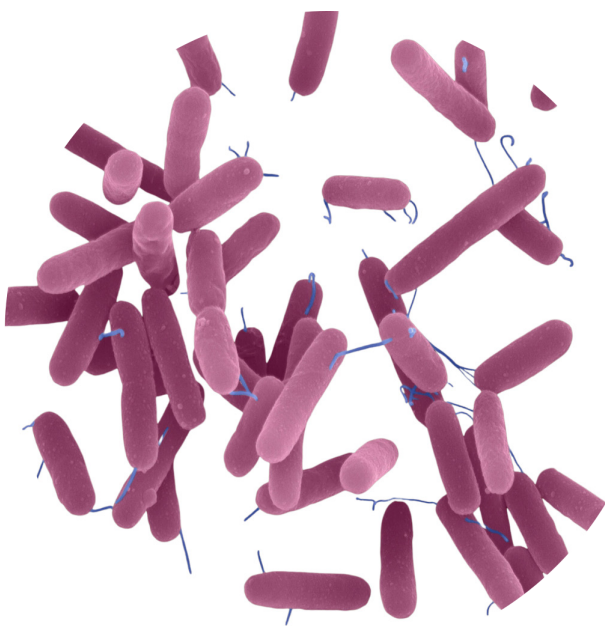
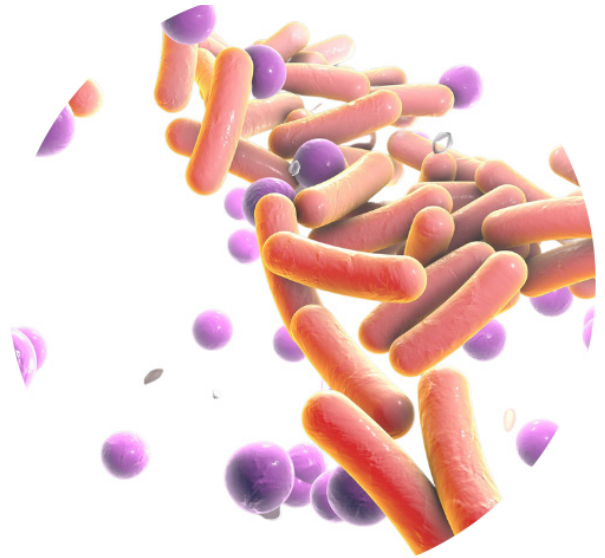

Pseudomonas Aeruginosa

Pseudomonas Aeruginosa is a common bacterium, capable of causing disease in plants, animals, and humans. Known for its intrinsically high level of antibiotic resistance, this bacterium can prove incredibly dangerous to immunosuppressed people. Unfortunately, pseudomonas aeruginosa is capable of thriving up to two metres before point of use, meaning not only the outlet but everything leading up to it, including pipework and the waste trap can become contaminated. Preventing pseudomonas aeruginosa necessitates the regular flushing of taps and fitting outlets without plastic parts that avoid retrograde contamination risks.

E. Coli

Escherichia coli (E. coli) bacteria are frequently found in the intestines of humans and animals. E. coli is often spread through water contaminated with fecal matter, leading to further, serious illness in the form of severe stomach cramps, bloody diarrhoea and vomiting. Like other water-borne pathogens, regular hand washing, flushing and temperature control are vital in preventing any further spread of serious illness.

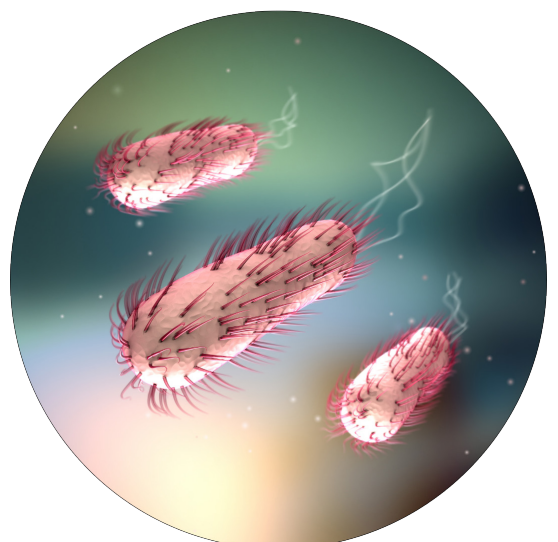

The shortcomings of traditional water monitoring

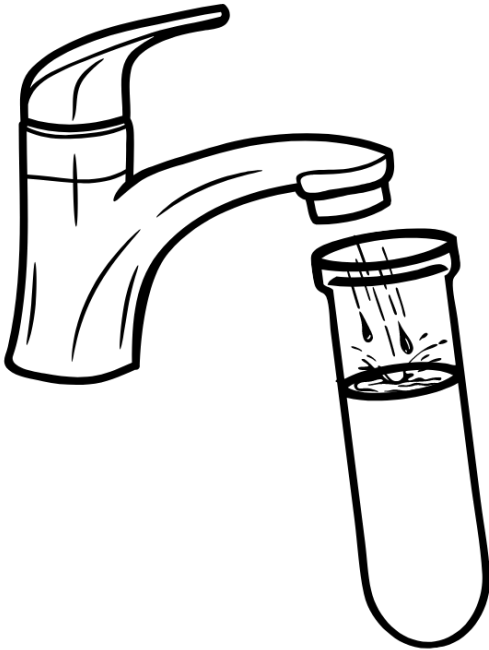

Water testing missing the mark

Currently it has become commonplace to blanket test water systems in order to find any underlying issues. However, this method is expensive and the required results can take time before they are received, increasing risk to the public and those using the building. Exacerbating the issue, water testing is often done separately from temperature testing, leading to inaccurate and poor risk assessments. Blanket, sporadic testing can often miss certain problem areas within systems, allowing them to grow until they become a much greater issue, leading to much-needed and costly remedial works.

Lack of biofilm monitoring or leak detection

In the event of biofilm growth or even a leakage in the system, traditional methods fall short of preventing these incidents from happening in the first place. Testing for biofilm growth is another symptom of reactive maintenance, as the biofilm can already have spread and proliferated throughout the system before it is identified and dealt with. By the time the leak has been logged and recorded, many litres of water can already have been wasted, when concerning larger leaks this can even total in the hundreds or thousands by the time remedial works have been carried out. What's more, these leaks can lead to expensive insurance claims as they damage essential equipment and even entire rooms or areas of the building needing to be shut for maintenance.

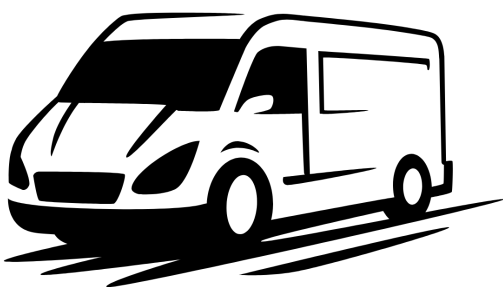
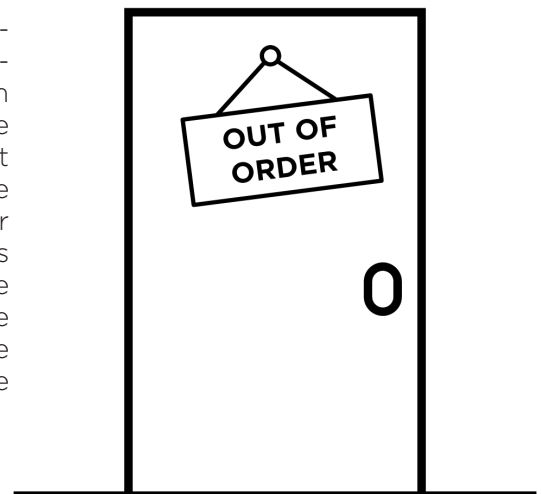

High carbon emissions

Traditional water monitoring often relies on contractors travelling to each site individually, often in vans which can very quickly add up in terms of CO₂e given that the average van emits 0.05 tonnes of CO₂e every 100 miles travelled.

Lack of accessibility

As stated previously, manual water testing can only give you effective results after a certain period of time has passed and will not give an accurate report of the health of your whole water system. These results are usually given out in one format and can often be difficult to read and interpret. Results can also be difficult to access online, wherever and whenever you need them and often come from different sources, complicating risk assessments. Identifying patterns of flow and temperature variations becomes almost impossible under these conditions.



Investment of time and money

At present, traditional water monitoring places great importance on using personnel over lengthy periods of time, in order to manually test every outlet in a building. A clear issue arises in that many hours are spent to acquire test results that only give a glimpse into a water system's health, and furthermore only at the exact time of monitoring. These results are therefore historic and often mis-identify the risks within the water system.

Introducing Clarence: A Revolution in Remote Water Monitoring

Monitors flow events and temperature simultaneously

The Clarence system is capable of measuring flow events, informing users how often their outlets are used. Flow event analysis for more targeted and effective managing of water systems, paving the way for improvements to be made to optimise water flow and reduce water wastage. Simultaneously, the Clarence system is capable of measuring multiple hot and cold water temperatures, ensuring that your water adheres to temperature compliance. Monitoring applies to both static and recirculated water. The C-1 is capable of measuring two temperatures simultaneously, whereas the O-1 is capable of measuring up to four temperatures simultaneously. The Clarence system isn't restricted to either hot or cold temperatures, as the system is capable of measuring mixed water temperatures, (post TMV) and hot water return pipe temperatures, to allow for a truly holistic and safe picture of your water system.

C-1 Features

- * Unique biofilm sensor(s) monitors pathogens and biofilm
- * Hot, cold, mixed and return water temperature measuring capabilities
- * Capable of measuring up to 2 temperatures simultaneously
- * Measures flow events
- * Leak detection
- * TMV failure detection
- * 4G/5G connectivity



Clarence System C-1

Unique biofilm sensor

The C-1 is the world's first remote water monitoring box capable of detecting biofilm and pathogens within flow, picking up readings as low as 6 CFUs (Colony Forming Units). Being able to detect biofilm and allowing preventative measures to be taken. This greatly helps to prevent severe health risks from occurring.

Remote monitoring at your fingertips

Installation of either C-1 or O-1 includes access to our cloud-based water management system Seraph Protect. Seraph Protect allows organisations to monitor their entire water system, accessing the data remotely and securely no matter where they are. Seraph Protect also displays easy to read colour coded risk levels, starting from green to indicate safety, down through yellow and orange, culminating in red to indicate a potentially dangerous risk.

Clever system, simple installation

The Clarence system includes both the C-1 and the O-1, both of which are very simple to install. Installation of C-1 only requires a small section of pipework to be removed in order to fit the in-line bi-ofilm sensor. The monitoring box then simply needs to be attached to the pipework with the fixings provided. Installing the O-1 only requires itself and sensors being fastened to the pipework with the fixings provided. Once plugged into their respective sockets, the box can be commissioned within minutes and data is already being collected and displayed on Seraph Protect.



Clarence System O-1

O-1 Features

- * Hot, cold, mixed and return water temperature measuring capabilities
- * Capable of measuring up to 4 temperatures simultaneously
- * Measures flow events
- * Leak detection
- * TMV failure detection
- * LoRaWAN connectivity
- * Battery powered

Increases compliance

The Clarence system is highly effective in identifying issues within water systems, whether it be temperature, flow or even biofilm. Seraph Protect will alert you, allowing for a targeted deployment of the required countermeasures in response to any issue - improving and exceeding compliance levels.

Reduces cost

The Clarence system is constantly alert, monitoring a breadth of parameters 24/7, reducing the need for unnecessary flush testing and lengthy, costly manual temperature monitoring. Working in tandem with Seraph Protect allows the Clarence system to ensure better targeted water testing and disinfection, saving time and money.

TMV failure detection

Both the C-1 and O-1 feature a TMV failure detection system, capable of alerting users in the event of their water exceeds safe temperatures after the water has passed through a TMV. Once recorded, an alert is sent from Seraph Protect to the responsible persons, helping towards a swift resolution.

Leak detection

As the C-1 and O-1 are capable of measuring flow events, they are also designed to detect leaks within the water system. With an ongoing flow event lasting longer than typical outlet usage, the system will then record the event, sending an alert through the online dashboard Seraph Protect to the persons responsible, allowing you ample time to organise necessary maintenance.

Features	C-1 Box	O-1 Box
Biofilm Sensor	✓	
Hot & Cold Temp Sensors	✓	✓
Flow Event Reading	✓	✓
Seraph Protect Portal	✓	✓
4 x Temp sensors available		✓
Mains Powered	✓	
Battery Powered		✓
Lorawan Connectivity		✓
4G/5G Connectivity	✓	
Range Indicator Light		✓
TMV Failure	✓	✓
Leak Detection	✓	✓

Communication and connectivity

The C-1 and O-1 Clarence system devices utilise the latest in communication technology, including 4G/5G and LoRaWAN. To optimise connectivity, the C-1 and O-1 operate on different frequencies.

4G/5G transmission

The C-1 uses a 4G/5G connection in order to securely transmit recorded data directly to Angel Guard's secure cloud system Seraph Protect. Data from the C-1 is sent every 15 minutes, ensuring that all the data you receive is up to date, and that any issues are brought to your attention as soon as possible

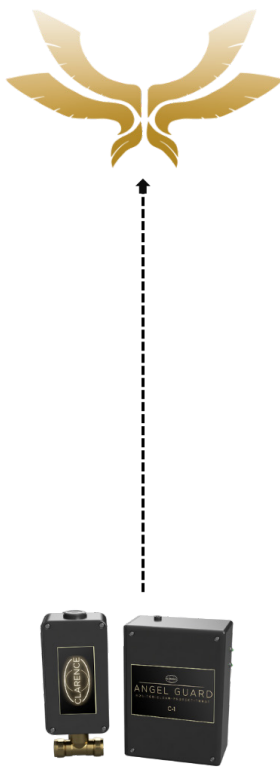

Clarence System C-1

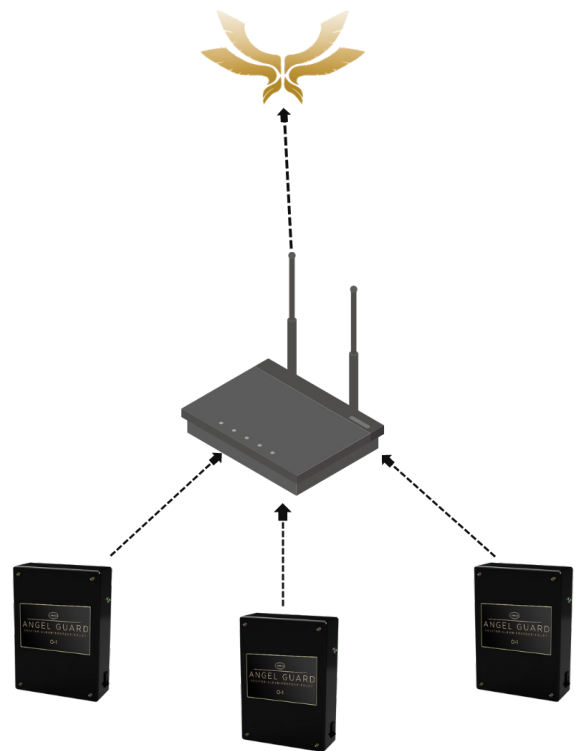

Clarence System O-1

LoRaWAN utilisation

The O-1 utilises a LoRaWAN (Long Range Wide Area Network) connection to transmit data to a hub, which then transmits the data to Angel Guard's cloud system Seraph Protect via either 4G/5G LAN or WiFi. LoRaWAN is ideal for areas with thick walls, as the O-1 transmits data at a very low frequency, capable of being positioned up to 1.2km away from the hub. Each O-1 features a light on its side, so you can be sure at a glance that your O-1 device is connected to the hub. As 25 boxes can connect to one hub, there is a significant reduction in data costs, as only the hub transmits directly to the cloud.

Seraph Protect: Compliance, 24/7



Water system management, any time, any place

Installation of the Clarence system includes access to Angel Guard's cloud-based water management system Seraph Protect, allowing authorised personnel to keep on top of and increase their compliance, tracking flow events, water temperature and biofilm levels. Seraph Protect creates real-time reports and provides risk level indicators on an easy to read portal accessible from any device.

What can Seraph Protect do for you?

- * Clarence system monitoring dashboard, displaying both C-1 and O-1 device data.
- * Simplified view, allowing users to understand data at a glance.
- * Through use of intelligent AI algorithms, evaluates water health and gives an easy to understand risk indicator, from green to yellow to orange and then red.
- * Device trend graph, highlighting water health over a chosen period of time.
- * Pop-up view allows users to attach documents to each device, including notes and calibration data.
- * Device Details section clearly displays linked outlets, maintenance and servicing statistics.
- * Easily accessible trend reports for all data and graphs, identifying flow events, temperature readings and biofilm levels.
- * System sends alerts only if and when you need them.

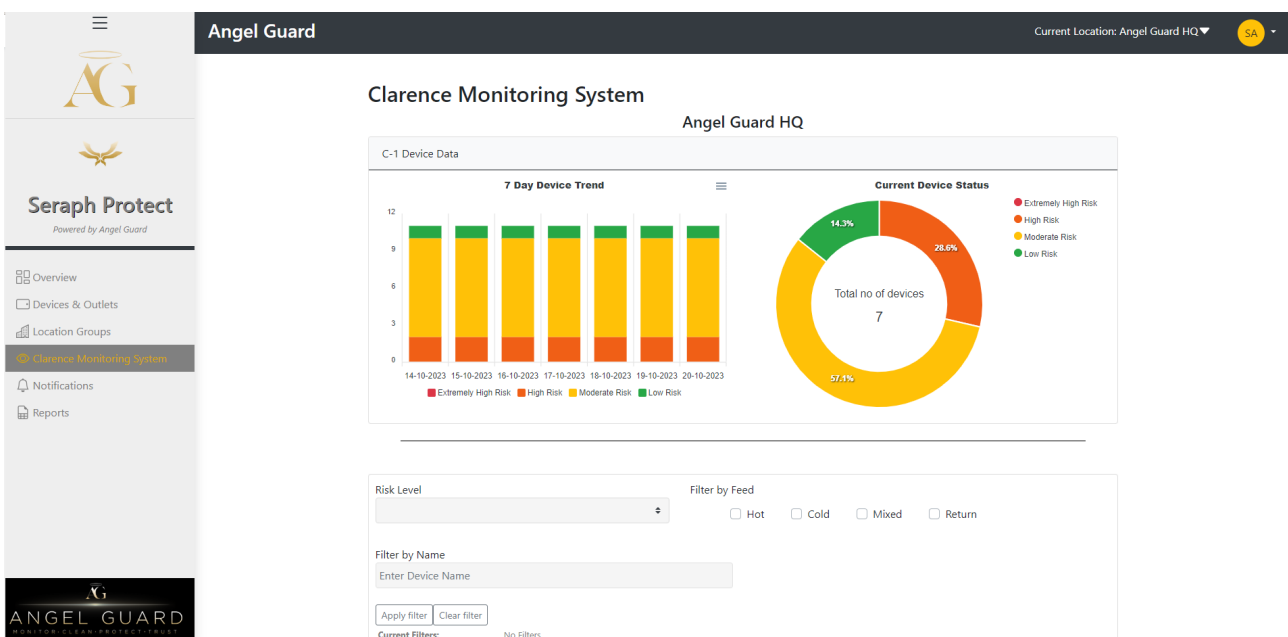

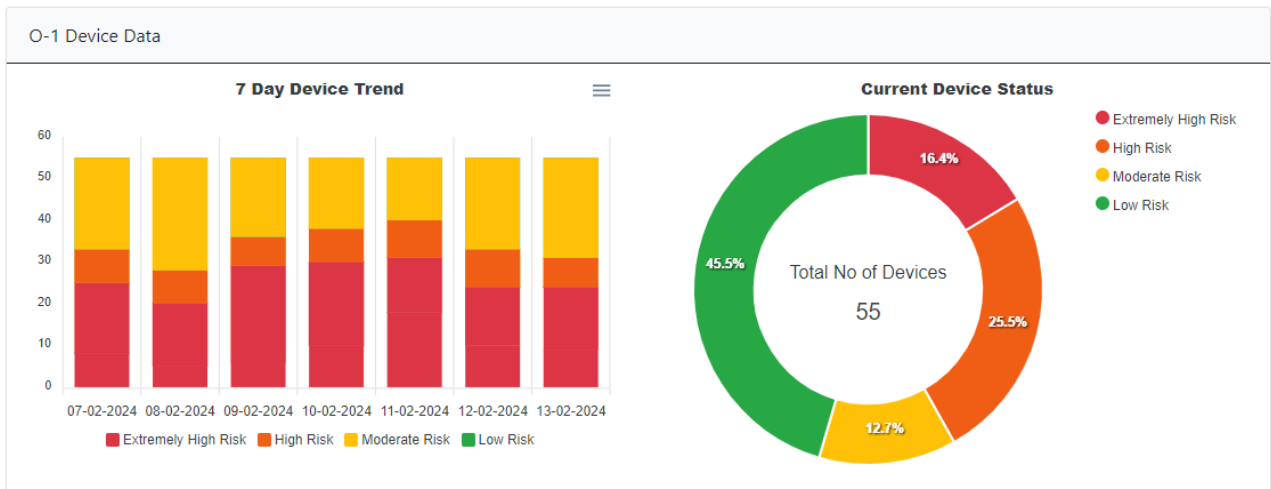

Angel Guard

Current Location: Angel Guard HQ SA

Location Groups

Angel Guard HQ

Location Groups
Location Group Management
Location Group Devices
Location Contacts

Factory Demo Group

Notifications 2

EndPoints 7

Devices 27

2
3
14
2

Details

Bathroom Zone 1

Notifications 37

EndPoints 1

Devices 7

0
1
3
0

Details

Factory General Test

Notifications 24

EndPoints 0

Devices 4

0
1
2
0

Details

SubG Test

Notifications 12

EndPoints 0

Devices 1

0
1
0
0

Details

Office Group

Notifications 0

EndPoints 0

Devices 0

0
0
0
0

Details

Bathroom Test Group

Notifications 0

EndPoints 0

Devices 0

0
0
0
0

Details

When accessing Seraph Protect, all data used and held is handled securely and in line with current GDPR guidelines. Angel Guard promises that your data is under the tightest encryption and has extensive failsafes in the highly unlikely event of any data breach. To guarantee further security, no sensitive or identifiable data is sent from any Clarence system device.

Seraph Protect makes commissioning C-1 and O-1 devices simple, as easy as scanning a QR code and completing the appropriate information on the linked page.

With Seraph Protect, it is easier than ever to understand and sort through your notifications. Angel Guard has made sure that all notifications for the Clarence system are grouped by area, to allow users to quickly understand where any issues have arisen. With a few clicks, you can filter notifications by priority or escalate issues directly to Angel Guard, where a highly-trained member of staff will be on hand to lend assistance.

Increases compliance, saves cost

Compliance is at the heart of the Clarence system. Presently, building operators and owners are all required to meet and comply with strict HSE guidelines with regards to managing the risks that water-borne pathogens pose. Current guidance, namely HSG274, states that to adequately manage water risks, frequent temperature checks are to be carried out for both hot and cold water across the entire building. The Clarence system has also been designed to be installed within healthcare settings, and as such has been made to comply with HTM 04-01.

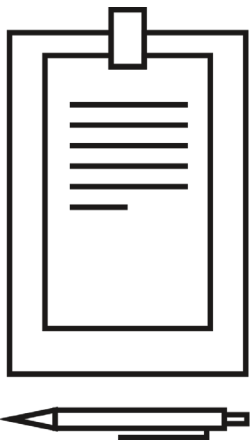

Temperature and flow

Present guidelines state that circulated water must be kept at certain temperatures. Through the Clarence system combined with Seraph Protect, constant data is being recorded to ensure that water temperatures are staying within their safe and recommended temperatures to comply with HSG274 and HTM 04-01. Additionally, the system is capable of measuring flow events, to ensure that compliance is being met regarding outlet usage. In the event of outlets failing to comply with these standards, water can become stagnant or outlets can become contaminated, especially concerning legionella and pseudomonas aeruginosa.

Outlet usage statistics

Currently, a majority of the data gathered surrounding usage statistics for water outlets is gathered on an ad hoc basis, which can be unreliable as it depends on the day, perfect note taking and continuous vigilance. Through gathering and collating data on flow events, the Clarence system creates easy to understand reports displaying how often each outlet has been used. Large hospitals can have as many as 4,000 outlets, so using the Clarence system can mean costs savings of up to £240,000 per hospital, per year*, when compared to traditional flush testing methods.

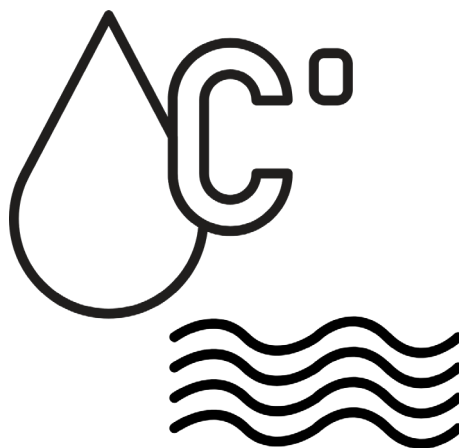

Scald risks

Combined with Seraph Protect, the Clarence system allows users to quickly evaluate the temperatures of their outlets, with minimum, maximum and average temperatures. Using these readings, users can effectively identify any scald risks within their building, eliminating the threat of scalding before serious harm is done. In order to prevent scalding risks, the Clarence system has been equipped with a functionality to specifically combat TMV failure. Utilising complex AI algorithms, the system is able to send alerts directly to Seraph Protect and specified responsible persons in the event of your TMV failing to keep your water temperature within the pre-programmed parameters.

* 10 staff members on around £24,000 a year, based on 4mins an outlet, 4,000 outlets, which means cost savings of around £240,000 per hospital

Targeted disinfections, minimising remedial works

Clarence monitors water in real-time and analyses biofilm levels as low as 6 CFUs. Due to a much greater accuracy of assessing risk levels at outlets and other points within the water system, Clarence provides the data for more targeted disinfection, reducing time and cost. Angel Guard reduces unnecessary remedial works to keep compliance consistently high, as the difference between single outlet disinfections compared to entire system disinfection can range from around £350 to £4,000 and far beyond. What's more, this figure does not factor in the time spent disinfecting, delayed production in manufacturing or closed wards in healthcare settings.

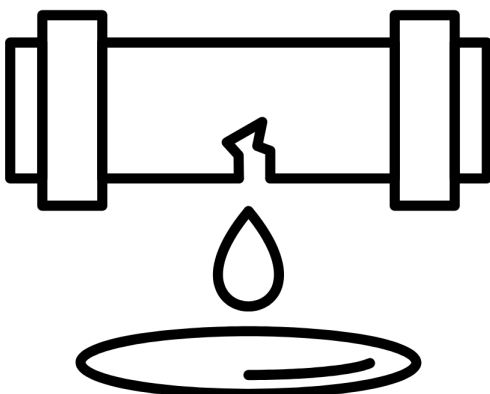

Water leaks

The Clarence system is capable of measuring flow events, meaning that through the detection of a continuous flow event, the system is capable of detecting leaks within your system faster than a manual test would provide results. Given that small leaks can vary from 6-12 litres of water an hour and larger, industrial leaks can range from between 400-600 litres of water an hour, the time between the leak occurring and the leak being detected is crucial, in some cases saving hundreds to maybe even thousands of litres of water. These leaks can also lead to further health and safety issues, causing widespread damp and having to close off whole areas of premises in some cases, not least considering the associated insurance costs incurred.

Case Studies and testimonial

Healthcare setting case study

Clarence installations within healthcare settings have already been proven very effective, in one instance within a neonatal care unit. Within this particular unit, the sink was used to clean baby's bottles, and Clarence discovered an extremely harmful growth of *pseudomonas aeruginosa* within both the pipework and sink tap. This was fortunately discovered very early and allowed remedial works to take place before any babies were infected.

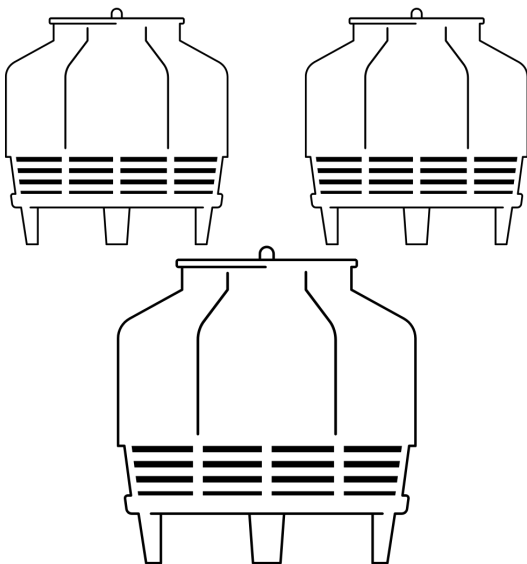
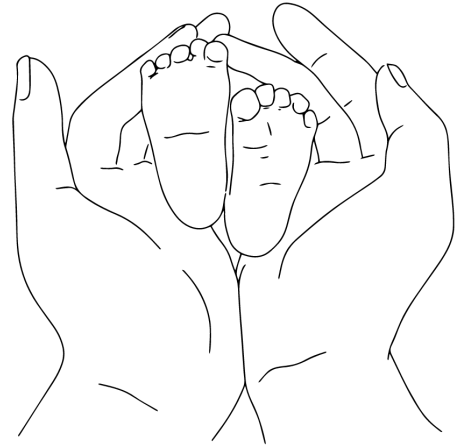

Cooling tower case study

Several cooling towers of a food and drinks manufacturing company had the Clarence system installed. The system was able to prevent a serious growth of legionella within three different cooling towers. Given the early warning that the Clarence system can provide, disinfection was able to be actioned immediately whilst avoiding a costly and dangerous outbreak.

Testimonial from Dr. Paul McDermott

On the subject of Clarence being installed within a hospital, Dr. Paul McDermott, world infection control practitioner and microbiologist has said, "I have no doubt that remote sensing technologies will bring enormous benefits to water safety. The ability to identify infrequently used outlets to ensure effective flushing is just one of the hard-to-crack nuts that this type of technology addresses. Its use as a means of monitoring water temperatures at frequencies far exceeding those advised in national guidance is another benefit that the technology offers. However, Angel Guard's Clarence system also has in-built technology to monitor the development of biofilms within water systems (especially in their early stages when it can more easily be addressed), setting it apart from other products."



Net zero targets

Angel Guard is committed to not only saving lives through the use of their remote water monitoring system, but also through its promise to help reduce its ecological impact on the environment. Keeping this ideal in mind, measures have been taken to ensure that the Clarence system will aid your clients and Angel Guard in achieving net zero goals.

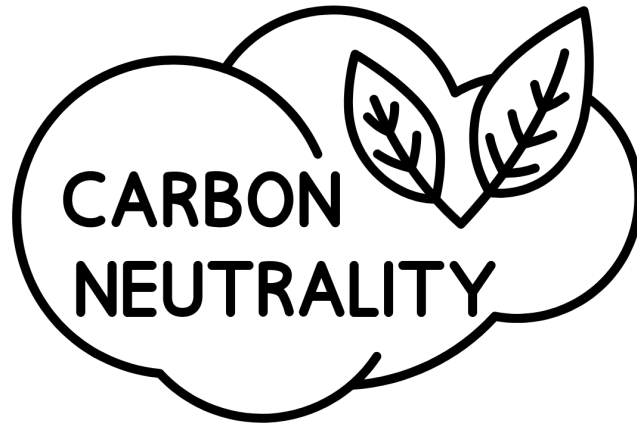

Carbon reduction

At present, constant maintenance has to be carried out in order to meet with compliance standards. These trips can add up to a staggering amount of carbon emissions. With the constant stream of data that the Clarence system provides, the amount of journeys needed to carry out the essential maintenance for a C-1 or O-1 box will drastically drop, significantly reducing CO₂e, by up to as much as 3.12 tonnes of CO₂e per van, per year.*

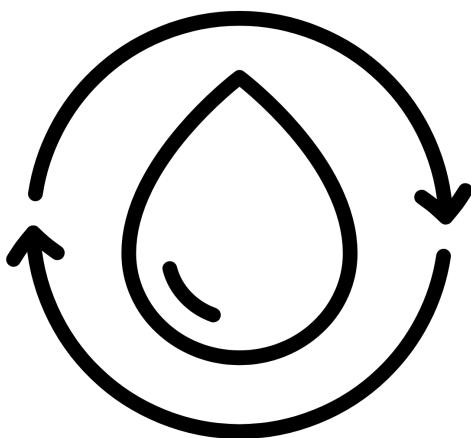

Reducing water wastage

Clarence provides real-time water usage data, reducing unnecessary consumption of hot and cold water through flushing. The system is also able to detect leaks, which can lead to high energy costs through water wastage. Angel Guard estimates that around 1,248 litres per outlet are used per year, in the case of a large hospital with around 4,000 outlets, this equates to around 4,992,000 litres in order to operate weekly flush testing for legionella. Clarence can reduce this by 90% through careful targeting, potentially saving 4,492,800 litres of water usage per year, per hospital.

* This is calculated with an average round trip distance of 60 miles, trip frequency of 2 per week with the average van emitting 0.05 tonnes of CO₂ per 100 miles.

Technical information

Technical information, always available

Angel Guard ensure that all technical information regarding their products is always made available online, ready for viewing at <https://www.angel-guard.co.uk/>

Installation instructions and maintenance manual

Angel Guard has produces an installation and maintenance manual for users to install and perform essential maintenance on their C-1 and O-1 devices.



Location indication leaflet

To ensure optimal placement of your C-1 and O-1 devices, Angel Guard have devised a short leaflet to suggest the best locations in which to install your remote monitoring devices.

Independent testing

In partnership with a prestigious university, Angel Guard have carried out numerous independent tests to ensure that the Clarence system performs to the highest possible standard. For more information on this, please visit the Angel Guard website at <https://www.angel-guard.co.uk/>

Associations

Angel Guards are members of several organisations, as well as being partnered with other organisations to deliver their world class service.

Snowbird Finance

Angel Guard recognises that in some cases, capital expenditure can be an issue, which is why Angel Guard have collaborated with Snowbird Finance Ltd, tailoring financial solutions to meet any circumstance with low monthly or quarterly payments. Please contact Angel Guard's dedicated staff for more information.

Snowbird
Finance Ltd
EXPERTISE | SERVICE | INTEGRITY



RSPH
ROYAL SOCIETY FOR PUBLIC HEALTH
VISION, VOICE AND PRACTICE

Royal Society for Public Health (RSPH)

Angel Guard is a corporate member of the Royal Society for Public Health (RSPH). As the aims of Angel Guard, and RSPH align, together they hope to create healthier environments, improve, and protect the public's health, made possible thanks to products manufactured by Angel Guard.

Made in Britain

As Angel Guard's products are manufactured within the United Kingdom, they are proud to promote their Made in Britain membership.





Product Data Sheet

Clarence C-1 Remote Water Monitoring Box with Biofilm Sensor

SKU	Description
C10054G	15mm Single-Pipe 4G Mains 1.2m
C10064G	15mm Single-Pipe 4G Mains 5m
C10074G	15mm Double-Pipe 4G Mains 1.2m
C10084G	15mm Double-Pipe 4G Mains 5m
C10094G	22mm Single-Pipe 4G Mains 1.2m
C10104G	22mm Single-Pipe 4G Mains 5m
C10114G	22mm Double-Pipe 4G Mains 1.2m
C10124G	22mm Double-Pipe 4G Mains 5m
C10134G	22mm Outdoor Single Pipe 4G Mains 5m
C1014EX	Replacement Biofilm Sensor



Material Type:

Controller Box: Black ABS

Sensor Box: Black ABS

Pipe Fittings: Brass

Weight:

Controller Box: 0.35 kg

Sensor Box: 0.325 kg

Notes:

Features & Benefits:

- Utilises AI Technology to monitor water temperature, flow events and includes a world-first sensor, capable of detecting the early stages of biofilm growth
- Takes readings every second and uploads all data to the Seraph Protect dashboard, allowing for remote access to device reports and live status
- The 24/7 data collection allows for improvements to compliance, and allows for targeted treatments of water systems
- Can be installed in to any existing pipework, in a variety of locations (healthcare, industrial, cooling towers, leisure, etc) *further details found in the Location Advice document*
- Installation is simple when using the accompanying *Installation Guide*



Product Data Sheet

Clarence C-1 Remote Water Monitoring Box with Biofilm Sensor

SKU	Description
C10054G	15mm Single-Pipe 4G Mains 1.2m
C10064G	15mm Single-Pipe 4G Mains 5m
C10074G	15mm Double-Pipe 4G Mains 1.2m
C10084G	15mm Double-Pipe 4G Mains 5m
C10094G	22mm Single-Pipe 4G Mains 1.2m
C10104G	22mm Single-Pipe 4G Mains 5m
C10114G	22mm Double-Pipe 4G Mains 1.2m
C10124G	22mm Double-Pipe 4G Mains 5m
C10134G	22mm Outdoor Single Pipe 4G Mains 5m
C1014EX	Replacement Biofilm Sensor

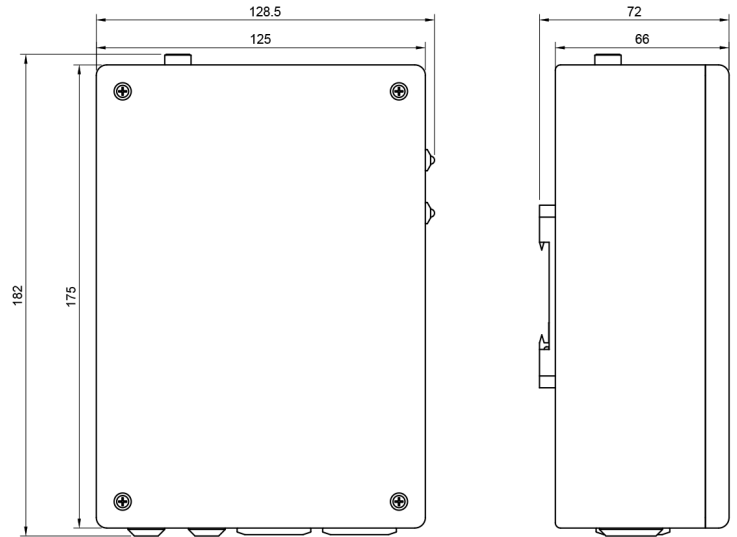

Controller Box

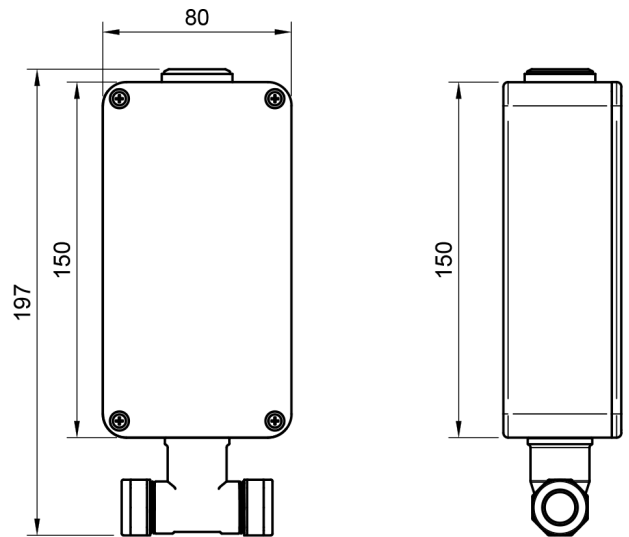

Sensor Box





Clarence O-1 Remote Water Monitoring Box

SKU	Description
C2000LW	O-1 Device with 1x Temperature/Flow Sensor
C2001EX	Additional Temperature/Flow Sensor
C2002EX	Additional Battery
C2003EX	Communication Hub #1
C2004EX	Communication Hub #2



Material Type:

Controller Box: Black ABS

Weight:

O-1 Device: 0.7 kg

Additional Temp./Flow Sensor: 0.02 kg

Additional Battery: 0.1 kg

Notes:

Features & Benefits:

- Helps keep buildings safe against the risk of water-borne pathogens, such as Legionella
- Measures up to 4 temperatures at once, for example – hot, cold, mixed and return-flow water
- All major flow events are recorded and stored
- Highly accurate data is wirelessly sent to the Seraph Protect cloud 24/7 and analysed using AI technology
- An up-to-date risk level is provided for every Clarence device, on the Seraph Protect dashboard, allowing for remote access to reports and live status
- Battery-powered, to allow for further flexibility during installation
- Devices communicate via a LoRaWAN hub (available) – reducing data costs considerably
- Easy to access, read, and understand risks, data trends and historic data – improving compliance



Product Data Sheet

Clarence O-1 Remote Water Monitoring Box

SKU	Description
C2000LW	O-1 Device with 1x Temperature/Flow Sensor
C2001EX	Additional Temperature/Flow Sensor
C2002EX	Additional Battery
C2003EX	Communication Hub #1
C2004EX	Communication Hub #2

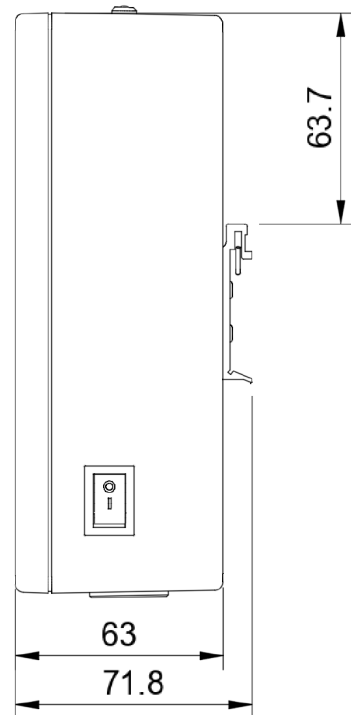
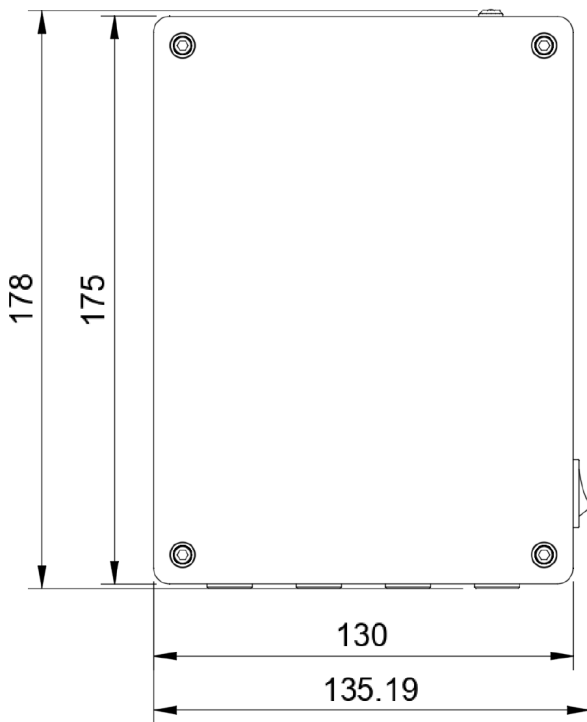

O-1 Device





Tel: 0141 280 9488 Email: info@angel-guard.co.uk

Website: <https://www.angel-guard.co.uk/>